

THJM

Multiple-Truss Hip/Jack Hanger

The THJM is a non-welded hanger designed to carry radial-end jack framing and provide optimal efficiency for those multi-plane, angled bay roofs over breakfast, study and library alcoves. The unique patented design of the THJM accommodates 2x4 girder bottom chords and uses our Strong-Drive® SDS Heavy-Duty Connector screws for easy installation with minimal fasteners.

Features:

- The THJM hangers are designed for installation with ¼" x 3" Strong-Drive SDS Heavy-Duty Connector screws that are included with the parts.
- The THJM2-4-SDS3 is designed for four incoming jack trusses with the outer jacks being 22½° from the face of the girder and the inner jacks being 45° from each other and the outer jacks.
- The THJM2-5-SDS3 is designed for five jacks coming into the hanger at 30° from the girder and each other.
- Tabs on the seats of the THJM assist in the placement of the jacks and also include obround holes for optional slant nails (0.148" x 1½") when increased uplift is required.

Material: 12 gauge

Finish: Galvanized

Installation:

- Use all specified fasteners; see General Notes.
- Each carried jack truss requires one ¼" x 3" Strong-Drive SDS Heavy-Duty Connector screw installed into the bottom chord through the bottom of the hanger seat.
- For installation on girders with 2x6 or 2x8 bottom chords, install one additional ¼" x 3" Strong-Drive SDS Heavy-Duty Connector screw in the triangular hole on each vertical strap.
- Install two 0.148" x 1½" slant nails in the obround holes on each of the seat tabs to achieve the additional uplift load noted in the footnote.

Codes: See p. 13 for Code Reference Key Chart

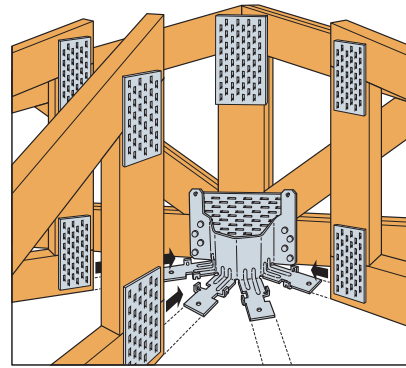
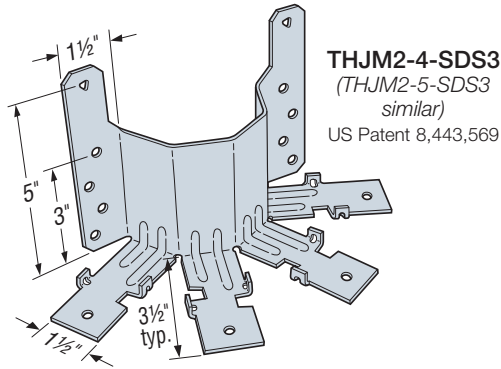

Typical THJM Installation

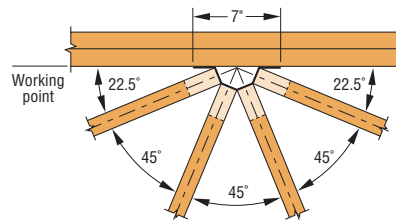

THJM2-4-SDS3
Top View Installation

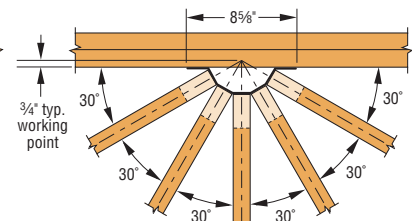

THJM2-5-SDS3
Top View Installation

Model No.	SDS Fasteners		DF/SP Allowable Loads					SPF/HF Allowable Loads				Code Ref.	
	Carrying Member ³	Carried Members (Total)	Total Uplift (160) ⁶	Total Download				Total Uplift (160) ⁵	Total Download				
				Floor (100)	Snow (115)	Roof (125)	Wind (160)		Floor (100)	Snow (115)	Roof (125)		Wind (160)
THJM2-4-SDS3	(8) ¼" x 1½"	(4) ¼" x 3"	535	2,000	2,300	2,500	2,585	535	1,440	1,655	1,800	1,865	IBC®, FL
	(8) ¼" x 3"	(4) ¼" x 3"	535	3,140	3,140	3,140	3,140	535	2,400	2,635	2,635	2,635	
THJM2-5-SDS3	(8) ¼" x 1½"	(5) ¼" x 3"	590	2,000	2,300	2,500	2,585	445	1,440	1,665	1,800	1,865	
	(8) ¼" x 3"	(5) ¼" x 3"	590	3,360	3,630	3,630	3,630	445	2,400	2,620	2,620	2,620	

1. Tabulated loads are the total allowable loads of all carried members combined; the load on any single carried member shall not exceed 25% of the total published load for the THJM2-4 or 20% of the total published load for the THJM2-5.
2. Uplift loads have been increased for earthquake or wind loading with no further increase allowed. Reduce where other loads govern.
3. A minimum two-ply carrying member is required for the ¼" x 3" Strong-Drive SDS Heavy-Duty Connector screws (provided). For single 2x carrying members, use ¼" x 1½" SDS screws (sold separately) with corresponding loads.
4. Truss chord cross-grain tension may limit allowable loads per ANSI/TPI 1-2014. The optional triangle holes may be used for installation on 2x6 and larger carrying members, for a total of 10 fasteners into the carrying member, to resist cross-grain tension forces when no other mechanical reinforcement is available.
5. Tabs on the seats of the THJM hangers have obround holes for optional 0.148" x 1½" slant nails (two per carried member) when additional uplift load is required. Total allowable uplift with the optional 0.148" x 1½" slant nailing is 760 lb. (DF/SP/SPF/HF).
6. Strong-Drive SDS Heavy-Duty Connector screws may be installed through metal truss plates as approved by the Truss Designer, provided the requirements of ANSI/TPI 1-2014, Sections 7.5.3.4 and 8.9.2 are met (pre-drilling required through the plate using a 3/32" bit maximum).